

Order code (standard unit)
Type

ID-No.:

RS6/539-559

655973

With track-control, output plug

Safety instructions

This description contains the necessary information for the correct application of the product described below. It is intended for use by technically qualified personnel.

Qualified personnel are persons who, because of their training, experience and position as well as their knowledge of appropriate standards, regulations, health and safety requirements and working conditions, are authorised to be responsible for the safety of the equipment, at all times, whilst carrying out their normal duties and are therefore aware of, and can report, possible hazards (Definition of qualified employees according to IEC 364).

WARNING!
Hazardous Voltage!
Failure to observe can kill, cause serious injury or damage.
Isolate from mains before installation or dismantling work, as well as for fuse changes or post installation modifications.
Observe the prescribed accident prevention and safety rules for the specific application. Before putting into operation check if the rated voltage for the unit conforms with the local supply voltage.
Emergency stop devices must be provided for all applications. Operation of the emergency stop must inhibit any further uncontrolled operation.
Electrical connections must be covered.
The earth connection must be checked for correct function, after installation.

Specified Use
The units described herein are electrical controllers for installation in industrial plants. They are designed for power adjustment on vibratory feed equipment.

Electrical Rating
Units are rated for 230 V or 110 V, 6 A

Control elements

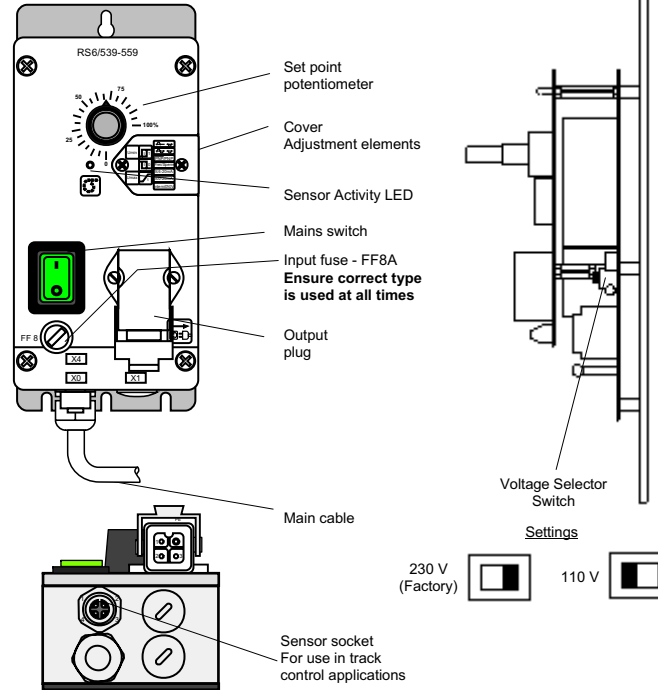

Settings

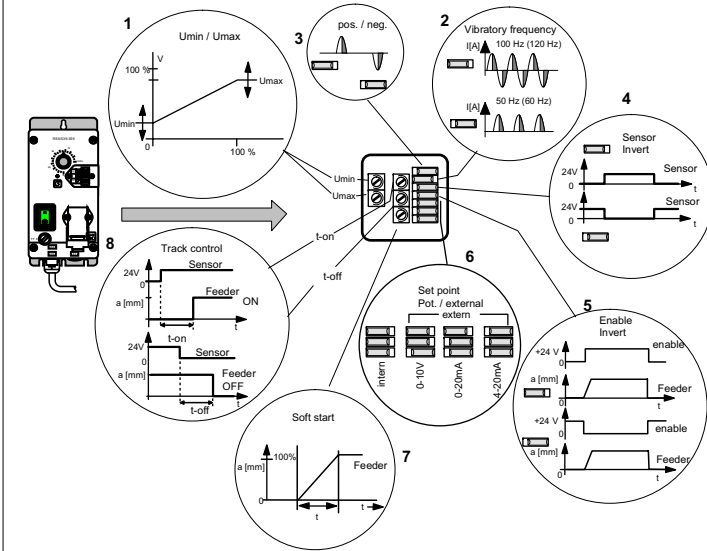

! Only Adjust Links and Trimmers when unit is isolated from the mains supply

Installation

! Check!	Do supply voltage, operating voltage of the conveyor and controller input voltage match ? Is the controller adequately rated for the rated power of the feeder ? What is the vibratory frequency of the feeder ?
	Connect the unit in accordance with the wiring instructions and ensure that earthing is correct !
! Attention!	A wrongly adjusted vibrating frequency may result in destruction of the connected coils! If half-wave is selected make sure that coils suitable for half-wave operation (50 Hz / 3000 vibs./min or 60 Hz /3600 vibs./min.) are used .

Settings

- Set-point control range: Scale the usable control range of the feeder by using trimmers Umin and Umax.
- Vibrating frequency setting: Select 50 Hz or 100 Hz (for 50 Hz mains supply); 60 Hz or 120 Hz (for 60 Hz mains supply).
- Selection of half-wave polarity. (when several controllers are used). To reduce mains distortion for applications using 50 (60) Hz mechanical frequency, the controllers are used on different half-waves.
- Invert sensor: Change the logic function of the sensor input.
- Invert enable: Change the logic function of the enable input.
- Set-point source: Change the external set point source to 0...+10 V, DC voltage signal ; 0... 20 mA or 4... 20 mA current signal.
- Soft start: Start-up time ramp adjustment.
- Track-control time delays: Switch on time delay when sensor calls for product. Switch off time delay when sensor indicates that no more product is required

External connections

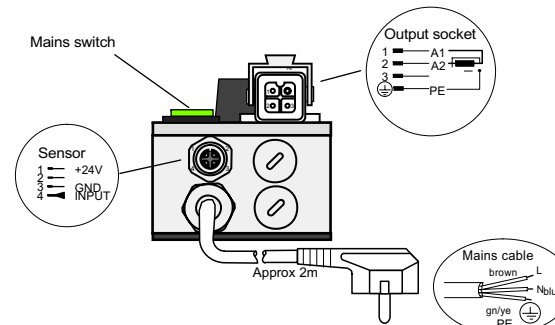

Internal connections

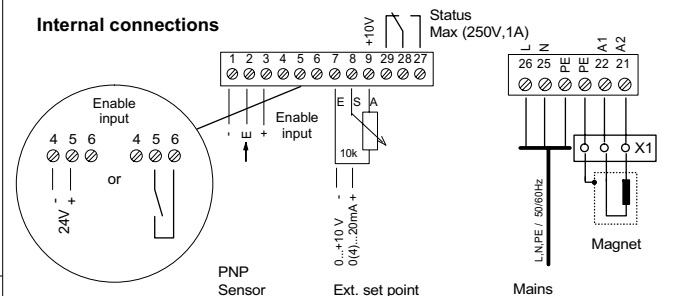

Dimensions

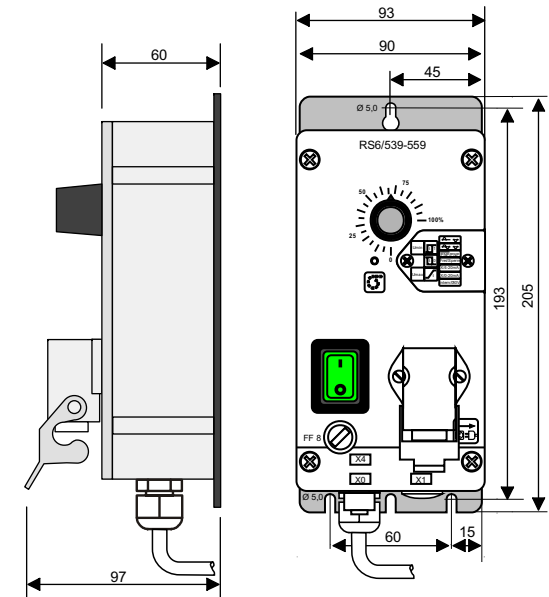

Olympic Automation



Tel: 01283 711 117 e-mail: enquiries@olympicautomation.co.uk
Mob: 07887 700 818 web: www.olympicautomation.co.uk

Accessories

Output plug: 3+PE HA-4-K / 090212
Sensor plug: M12, 4PIN RSV-M12-4 / 090131