

REOVIB MFS168

Versatile variable frequency digital control unit

The 168 brings unsurpassed levels of reliability, versatility and performance to the Electromagnetic Feeder world.

The unit combines ease of use with the very latest technology - problems with feed rate or difficult products can be solved instantly, simply by altering the frequency.

The unit can be used with an accelerometer, Type SW011 to provide constant feed



Important Features

The MFS168 has the following as standard

- Dual Voltage input 110 V or 230 V
- Digital Display
- Touchpanel for easy adjustment of parameters
- **Variable Frequency - see below**
- **Mains Input Stabilisation - see below**
- **Constant Feed Rate - see below**
- Input for Track Control Sensor
- Synthesised output waveform
- Passcode access to important functions
- Remote speed and On/Off control

Special Function - Variable Frequency

The 168 range allows the user to set the output frequency to within 0.1 Hz. This is totally independent of the mains input frequency, so you can be assured that your system will operate just as well overseas, also fine-tuning of systems can be made quickly and cost effectively and some products are able to be fed much more effectively at special frequencies.

Special Function - Mains Stabilisation

REO controllers have inbuilt stabilisation electronics, which constantly monitor the mains input and adjust the output level accordingly ensuring that the feed rate is maintained.

Special Function - Constant Feed Rate

When used with an SW011 accelerometer the 168 is capable of maintaining feeder speed, irrespective of variable loads or changes in feeder dynamics. This enables the system to run smoother and more efficiently and allows easier intergration into larger processes.

Technical Specification - MFS168

Supply voltage	110/230 V, 50/60 Hz auto setting
Output frequency	Adjustable between 8 and 140 Hz
Output current	max 6 A total current
Soft start	0...4 secs
Soft stop	0...4 secs
Sensor supply	24 V, 25 mA
Switch ON time delay	0...15 secs
Switch OFF time delay	0...15 secs
Empty time	30...240 secs
Enable	12-24 VDC / Volt-free contacts
Status Output	250 V, 1 A relay
Operating temp	0...45 degrees C
Dimensions	90 x 205 x 186 mm
Enclosure	IP54

Input Controls

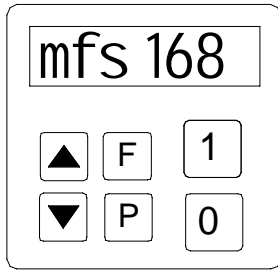

The six buttons and a LED display found in the front panel, are used for operating and setting up the unit. All operating methods and adjustable parameters can be set up through this panel.

The "1" and "0" buttons are used for switching the unit ON and OFF, however, these do not provide mains isolation, they simply inhibit the power semiconductors

The "P", "F" are used to enter passcodes and navigate within the setup menus

"Cursor Buttons" are used for parameter adjustment. Parameters are set by using menu controls which are called up by entering operator codes. A capital letter is used to indicate the selected function.

Setting adjustments are automatically saved upon leaving the programming mode or if no button is pressed for a period of 100 secs

Code 096 - Feeder Speed

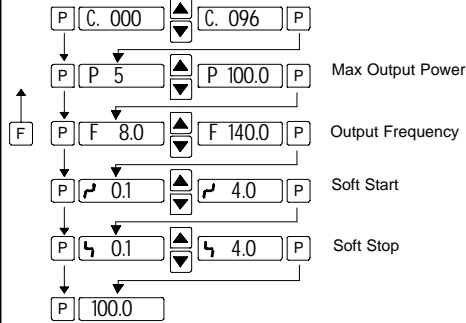

Note:
Display reads OFF, when external enable signal is removed.

Code 167 - Track Sensor Parameters

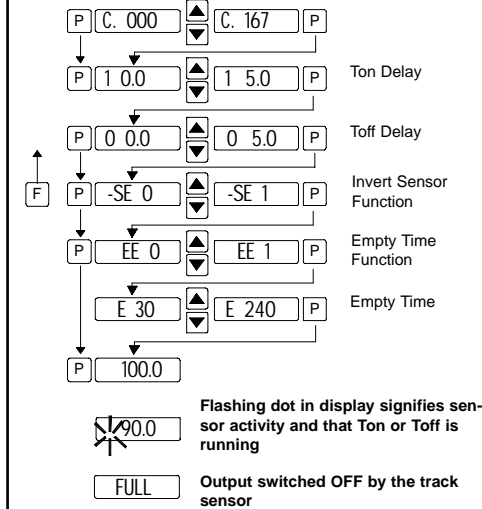

Code 008 - Accelerometer Functions

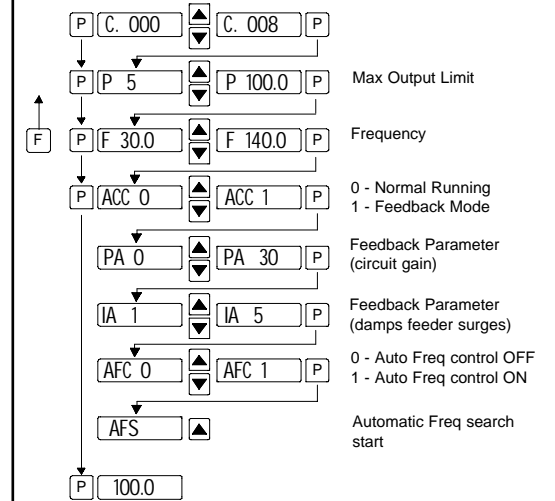

Code 002 - Feeder Speed

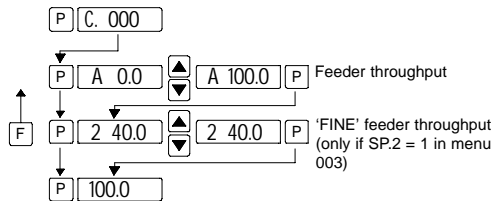

Code 143 - Save Current Settings

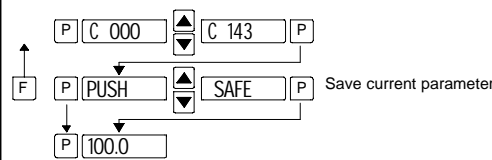

Code 117 - Hide Settings

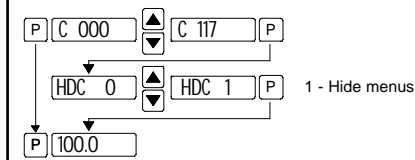

Display Indications (Regulation Mode Only)

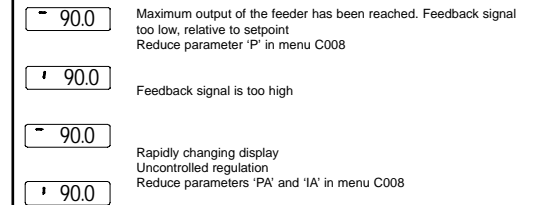

Code 003 - Setpoint source

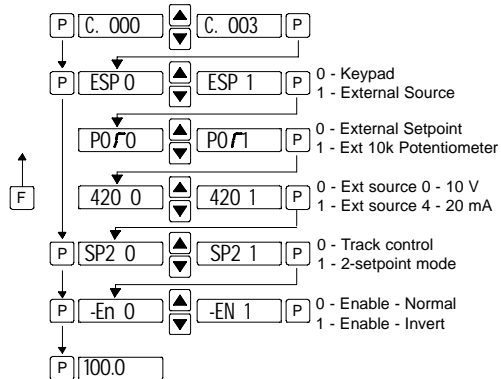

Code 210 - Re-instating Settings

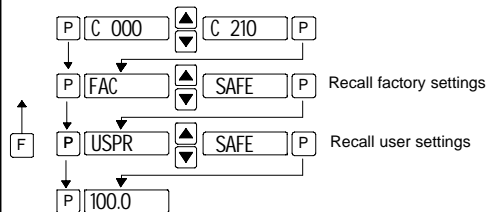

Error Messages

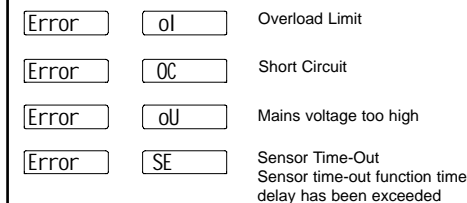

The unit can be reset by pressing the 'P' key

Optimising controller in regulation mode

Setting the Control range
1. In Menu C096 set parameter 'P' to 10%
2. Set 'A' (feeder throughput) to 100%
3. Increase 'P' from 10% until the required throughput is achieved

The full adjustment range 'A' of 0...100% can be used

Optimising regulation: For unwanted feeder oscillation (hunting) or inadequate feedback regulation for load changes
The response of the regulation circuit can be adjusted in menu C008 using the parameter 'PA' or 'IA'

Reduce 'PA' in C008 until the oscillations are reduced

Parameter 'IA' should be set to '0' or the lowest possible setting

Application Notes: Installation and Environmental Considerations

Applicable to all controllers

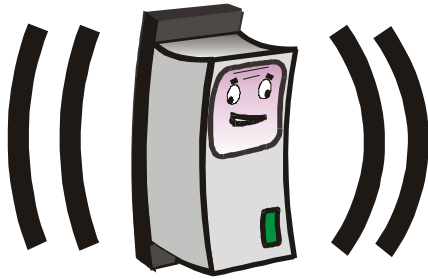

Vibration

All controllers house sophisticated electronics, which can be damaged if subjected to prolonged levels of vibration - ideally mount in a vibration free environment

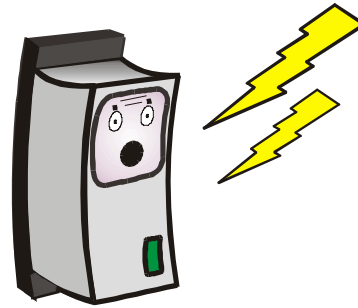

Voltage Spikes

Welding equipment, Motor Drives and Thyristor based controls can all create high energy spikes or transients which can affect the performance of controllers in some circumstances. If you suspect the presence of such phenomena contact your supplier



Temperature

The controllers are designed to run in an ambient temperature of 45 degs MAX. Any increase in temperature will have a detrimental effect on the performance of the controller. Ensure control units are adequately cooled!

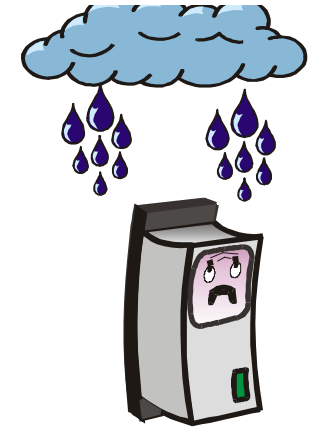

Moisture

Pay attention to the Ingress Protection (IP) rating of your controller. Most controls are sealed against dust and water splashes only. NOT POWERFUL JETS! If in doubt contact your supplier



Overload

REO controls are conservatively rated and are designed to run in demanding applications. However constant overloading, or mis-use can increase internal temperature beyond the rating of certain components



Electro-Magnetic Compatibility

High levels of radiated and conducted EMC interference generated by Motor Drives and Switch-Mode Power Units can interfere with the operation of REO controls - contact us for details of our EMC Filters

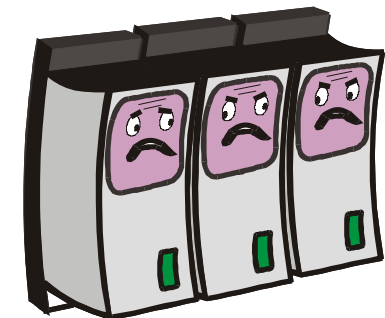

General

Allow at least 100 mm between controllers. Ensure units are adequately cooled. Try to avoid running Mains cables, Feeder Power cables and Signal and Control cables in the same loom or trunking